

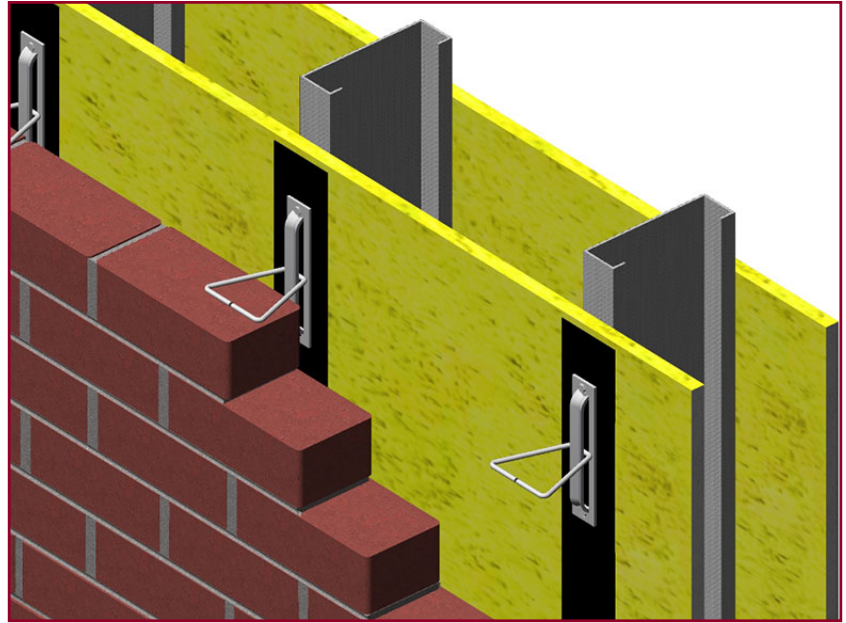

PRODUCT SUBMITTAL

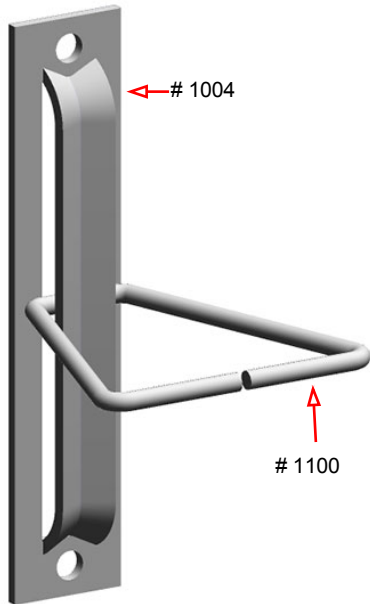

1004 Type III Screw On Veneer Anchor



MATERIAL CONFORMANCE	SIZES / FINISHES
<p>SHEET METAL - (Carbon Steel) ASTM A1008 / A1008M</p> <p>Mill Galvanized / Zinc Coating: ASTM A641 / A641M (0.10 Oz per sq ft)</p> <p>Hot Dip Galvanized after fabrication / Zinc Coating ASTM A153 / A153M-B2 (1.50 oz per sq ft)</p> <p>Stainless Steel ASTM 580 / ASTM 580M / ASTM A 666 Type 304 (Type 316 available on special order)</p> <p>ASTM A82 / A82M - (Cold drawn steel wire) Tensile Strength - 80,000 psi Yield Point - 70,000 psi</p> <p>ACI / ASCE 530 - (Building code requirements for masonry structures)</p> <p>Steel Products (flats): Mill Galvanized & Hot Dip, 59.2% Post-Consumer 8.8% Post Industrial / Pre - Consumer</p> <p>Stainless Steel, 60% Post Consumer V O C Content - 0%</p> <p>WIRE Recycled Content: Mill Galvanized & Hot Dip, 87% Post-Consumer 13% Post Industrial / Pre - Consumer</p> <p>Stainless Steel, 60% Post Consumer V O C Content - 0%</p>	<p># 1004 Type III: 1-1/4" wide x 6" long</p> <p><input type="checkbox"/> 14 gauge <input type="checkbox"/> 12 gauge</p> <p># 1100 Triangle:</p> <p><input type="checkbox"/> 3/16" diameter <input type="checkbox"/> 1/4" diameter</p> <p><input type="checkbox"/> 3"x3" <input type="checkbox"/> 4"x4" <input type="checkbox"/> 5"x5" <input type="checkbox"/> 6"x6" <input type="checkbox"/> 7"x9" <input type="checkbox"/> 9" x 9"</p> <p>FINISH:</p> <p><input type="checkbox"/> Mill Galvanized</p> <p><input type="checkbox"/> Hot Dip Galvanized</p> <p><input type="checkbox"/> Stainless Steel</p> <div style="text-align: right;">  </div>

Corporate Office: 400 Roundtree Rd Charlotte, NC 28217
TEL: (800) 849-6722 FAX: (704) 525-3761

Mailing Address: P.O. Box 240988 Charlotte, NC 28224



www.wirebond.com

Memphis Plant: 2365 Harbor Ave. Memphis, TN 38113
TEL: (800) 441-8359 FAX: (901) 775-9449

Mailing Address: P.O. Box 13124 Memphis, TN 38113

PRODUCT SUBMITTAL



1004 Type III Screw On Veneer Anchor Seismic

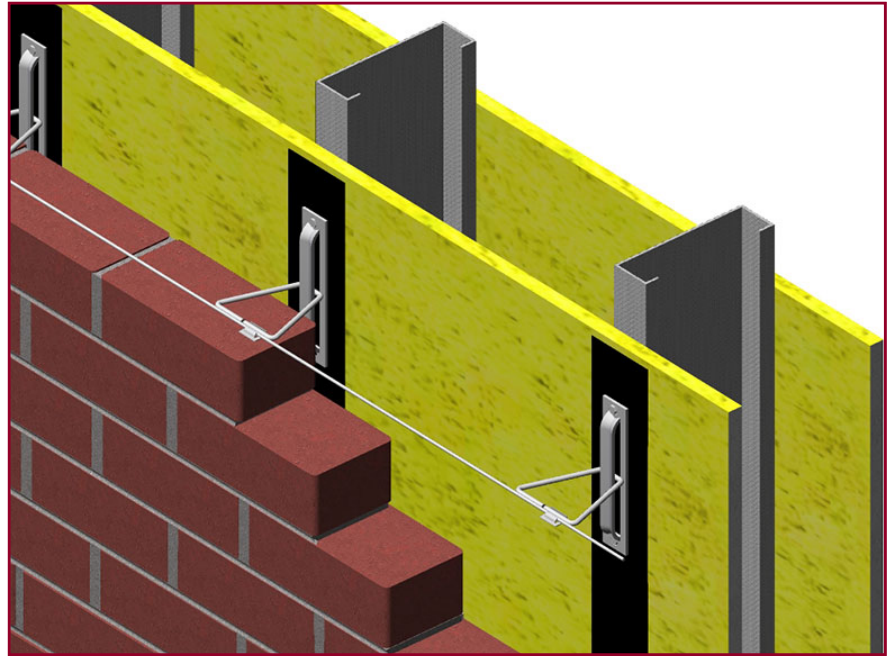
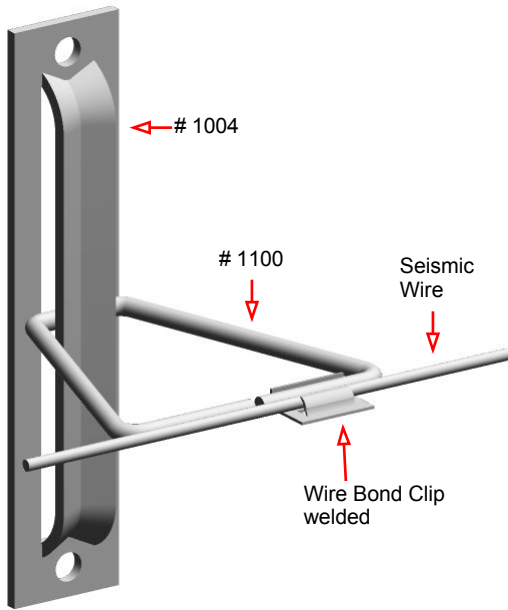

MATERIAL CONFORMANCE	SIZES / FINISHES
<p>SHEET METAL - (Carbon Steel) ASTM A1008 / A1008M</p> <p>Mill Galvanized / Zinc Coating: ASTM A641 / A641M (0.10 Oz per sq ft)</p> <p>Hot Dip Galvanized after fabrication / Zinc Coating ASTM A153 / A153M-B2 (1.50 oz per sq ft)</p> <p>Stainless Steel ASTM 580 / ASTM 580M / ASTM A 666 Type 304 (Type 316 available on special order)</p> <p>ASTM A82 / A82M - (Cold drawn steel wire) Tensile Strength - 80,000 psi Yield Point - 70,000 psi</p> <p>ACI / ASCE 530 - (Building code requirements for masonry structures)</p> <p>Steel Products (flats): Mill Galvanized & Hot Dip, 59.2% Post-Consumer 8.8% Post Industrial / Pre - Consumer</p> <p>Stainless Steel, 60% Post Consumer V O C Content - 0%</p> <p>WIRE Recycled Content: Mill Galvanized & Hot Dip, 85% Post-Consumer 13% Post Industrial / Pre - Consumer</p> <p>Stainless Steel, 60% Post Consumer V O C Content - 0%</p>	<p># 1004 Type III: 1-1/4" wide x 6" long</p> <p><input type="checkbox"/> 14 gauge <input type="checkbox"/> 12 gauge</p> <p># 1100 Triangle:</p> <p><input type="checkbox"/> 3/16"Ø <input type="checkbox"/> 1/4"Ø</p> <p><input type="checkbox"/> 3"x3" <input type="checkbox"/> 4"x4" <input type="checkbox"/> 5"x5" <input type="checkbox"/> 6"x6" <input type="checkbox"/> 7"x9" <input type="checkbox"/> 9" x 9"</p> <p>Straight & Cut Seismic Wire:</p> <p><input type="checkbox"/> 9 gauge <input type="checkbox"/> 3/16" diameter</p> <p>FINISH:</p> <p><input type="checkbox"/> Mill Galvanized</p> <p><input type="checkbox"/> Hot Dip Galvanized</p> <p><input type="checkbox"/> Stainless Steel</p> <div style="text-align: right;">  </div>

Corporate Office: 400 Roundtree Rd Charlotte, NC 28217
TEL: (800) 849-6722 FAX: (704) 525-3761

Mailing Address: P.O. Box 240988 Charlotte, NC 28224



www.wirebond.com

Memphis Plant: 2365 Harbor Ave. Memphis, TN 38113
TEL: (800) 441-8359 FAX: (901) 775-9449

Mailing Address: P.O. Box 13124 Memphis, TN 38113